

How to Create an Edmonds Flower Basket

General Guidelines

- **Select:** The City of Edmonds selects a variety of colorful annuals that can be used in hanging baskets and planting beds. Many of the plants used in the program are ordered from select seed catalogues throughout the United States and England. The baskets are packed with approximately 20 annuals.
- **Assemble:** The plastic containers used for the hanging baskets are polytainer #10 pots and polycan #6 for the smaller baskets. Corresponding plastic saucers are used inside the wooden baskets.
- **Mix:** The planting soil consists of equal amounts of peat moss, perlite and vermiculite, with small amounts of lime, bone meal, compost and time-release fertilizer. This specialized basket mix is rich in nutrients, yet lighter in weight than conventional mixes. Planting beds are enriched with compost generated from waste by-products recycled by City staff.
- **Time:** Flowers are potted into their final containers/baskets at the end of April and continue to be monitored and fertilized carefully to be sure that they are healthy. The corner parks are planted throughout May and June with baskets hung in June.
- **Water:** Watering is scheduled on Monday, Wednesday, Friday and as needed. During the growing season, several applications of water soluble fertilizer such as (12-31-10, 20-20-20, or 5-40-17) are applied as needed to insure optimum performance.

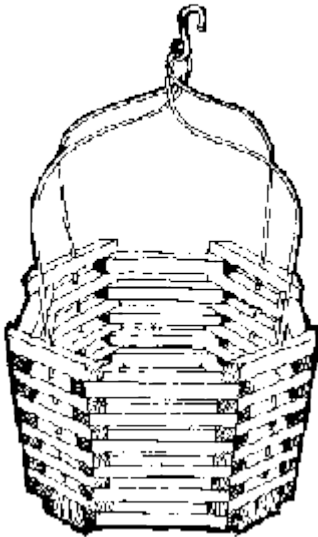

How to Construct a Basket

Materials List (for one basket 16-1/2" in diameter and 12" high)

Base: (2) 2" x 4" pieces 16-1/2" long

Stringers: (48) pieces cut at a 45degree angle on each end and measuring 8-1/2" long

Hanging Wire: 16' of 1/8" wire cable

Nails: (200) 1-1/2" galvanized finishing nails

Glue: 1 pint exterior construction glue

"S" Hooks: (1) about 3" high and 3/8" diameter

Staples: (4) heavy duty staples

Clamps: (2) wire clamps

Polycan: (1) #6 size

Instructions for Constructing a Hanging Basket

Constructing, planting and enjoying your own hanging baskets can be a rewarding experience. Although a modest degree of woodworking

skill is required, and certain power tools can be helpful, the project is not beyond reach of the

average homeowner.

The dimensions described are for the smaller of the two baskets used by the Edmonds Park Staff. Sizes can be altered by changing the stringers and base cross bars.

Creating a jig for cutting the stringers and drilling the pilot holes for the

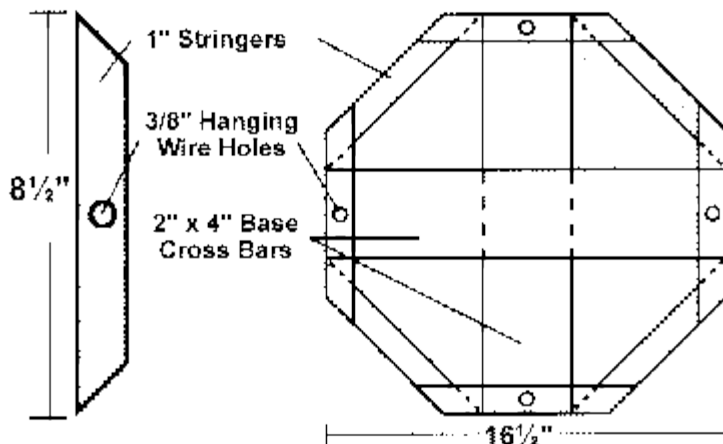

hanging wire will speed up the project and assure uniformity. All wood members are cedar without preservatives or stains.

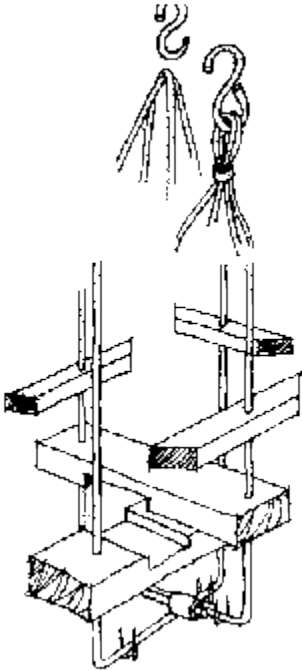

- Begin by laying out the basket shape on a piece of cardboard or heavy paper.
- Cut the stringers and base cross bars.
- Following your layout, drill 3/8" pilot holes for the hanging wire at each end of the base cross bars, and in half of the stringers. (When you have one stringer drilled, use it as a template for the remaining stringers to be drilled.)
- Lay out eight stringers on your pattern, apply a spot of glue to the under side of the overlapping stringers, and nail in position. Each vertical row of stringers should contain 6 stringers.
- 2" x 4" base cross bars can be added last.
- The hanging wire can be in one or two pieces, fed through the pilot holes and stapled to the underside of the base cross bar. The "S" hook is closed around the hanging wires and the wires are held together with a wire clamp or other suitable device.